

Installation and User Guide



Tools

These are the tools that you need to install Millboard.



Mitre saw/jigsaw/handsaw

Millboard decking boards can be cut with standard wood cutting tools (i.e. mitre saw, jigsaw, handsaw). We would recommend using a carbon-tipped saw blade.



Personal Protective Equipment

When handling Millboard products, it is advised to wear long sleeves and gloves. When cutting products it is advised to wear a FFP3 dustmask, ear defenders and safety glasses. Knee pads are recommended to be worn when fitting decking.



Power drill and driver

Standard Power drill drivers can be used to fix our Durafix® fixings through the boards. Impact drivers are not recommended to be used when fitting Millboard decking.



Tool set

Standard carpentry tools will be needed to complete the installation, including: tape measure, a pencil, set square, planer, stanley knife, surform and a drill bit set.

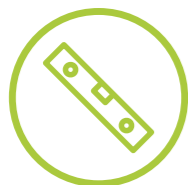

Spirit level

A spirit level is used to ensure that the subframe posts are set upright, as well as being used as a straight edge to ensure the joists/bearers are inline with each other.



String line

A string line is used to ensure the lines of the boards are started and finished straight.

Please ensure that you have read and understood our guidance prior to starting your project.



Millboard Installation and User Guide

Storage and handling

Millboard should always be stored on a flat surface or level bearers a maximum of 400mm apart and stacked face-to-face, not back-to-face.

Be careful not to drag the boards off the pallet or over each other, as this could cause abrasion or marking on the surface. Only move the pallet if the boards are safely strapped to it.

Wear gloves and long sleeves when handling the boards and take care when lifting them. We recommend that two people carry the boards.

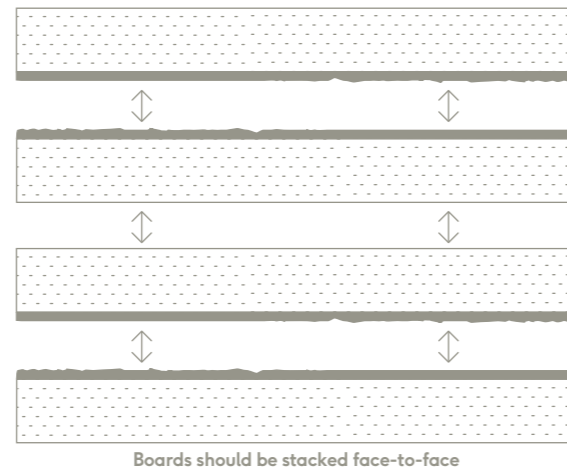

Colour

Millboard has been designed to replicate the natural variances of timber and is manufactured to have tonal variance in the colour.

Buying all the Millboard decking you need at the same time should help to ensure that the colour is consistent and we would always recommend laying out the boards before installation, to create an effective, subtle blend. Antique Oak boasts more tonal variation per individual board than any of the other colours in the Millboard range.

As with all things constantly exposed to ultraviolet light and all weathers, natural weathering will occur slightly in time, this is normal for decking. On delivery if you find the colour unacceptable or believe them to be defective in any way, please contact us.

It is best to lay boards out a day before installation, to ensure tone and grain variation is accounted for, and also to help the boards acclimate to the project location. If there are any foreseen issues with the boards, this should be highlighted with Millboard before installing.



Pre-install and framework

Millboard is a hand-moulded product, slight variance in the board dimensions should be expected. Tolerances we deem as acceptable are: length +/- 5mm, width +/-3mm, thickness +/- 2mm.

When working with the boards, packers may be required to create a flush finish between two boards. The boards may not be perfectly straight when they are delivered, they can be pulled straight by adjusting the gaps between the boards to be aligned with the string-line.

Please bear in mind that as the ends of the boards may need to be trimmed to make them square, this will reduce the length of the boards which could then affect the required joist spacing. We recommend that boards are laid to a slight fall away from the building to aid drainage.

Joist spacing of 400mm centres is recommended for normal residential use. On commercial use, bridges, balconies, moorings, doorways and steps, we recommend 300mm centres. If you need to cut Millboard down along the length, reduce the joist centres accordingly. A minimum of three joists is required for any cut boards (1).

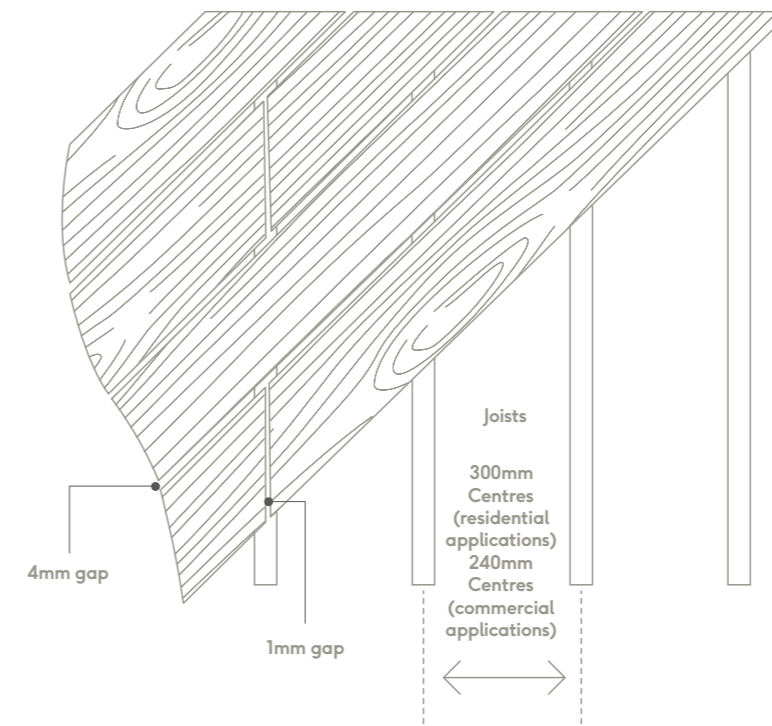
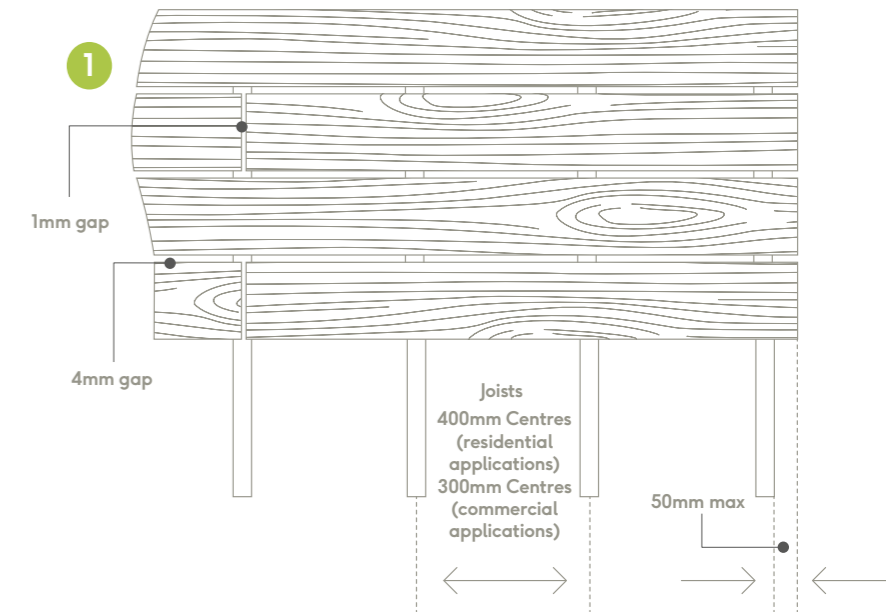

For laying boards 45° to the joist, reduce the joist centres to 300mm for residential and 240mm for commercial use, alternatively turn the joists round to be at 90° to the board direction.

Millboard products can be installed on to timber using the Durafix 4.5x60mm fixings, when fixing into Plas-Pro or DuoSpan the Durafix 4.5x45mm fixings should be used.

When fixing the fascia boards to 30mm or thinner battens the Durafix 4.5x35mm fixings should be used.

For more in-depth installation details on the DuoSpan or Plas-Pro please refer to our PDF installation guides and 'How to' videos on: millboard.co.uk/help-advice/

Millboard Installation and User Guide

Cutting products

Millboard products can be cut with standard wood cutting tools (i.e. mitre saw, jigsaw, handsaw), we recommend a carbon-tipped saw blade.

For cutting Plas-Pro, we recommend using a carbon-tipped ripping/multi-purpose blade. When cutting DuoSpan™ use an aluminium cutting blade.

Dispose of board off-cuts by sending to a municipal incinerator for energy replenishment, don't burn them at home. When cutting the boards, wear an FFP3 dust mask, safety glasses, long sleeves and protective gloves.

A dust bag or vacuum must be used on mitre saws. Make sure that the boards are adequately supported when cutting. Boards can be cut face-up or face-down.



Fastening to the substructure

The boards are secured using the Durafix fixings, they can be used through the face of the boards or through the side using the DuoFix side-fixing guide. When using the DuoFix guide, this should be used in accordance with the instructions on the DuoFix box, alternatively these can be found on - www.millboard.co.uk/help-advice/installation-guides.

When fixing the boards through the face with the Durafix fixings, there is no need to pre-drill or countersink, just drive the screw straight in. We advise using a standard driver with the bit provided and not an impact driver to fix the Durafix screws to the decking as this can break the drive bit and screw head, as well as impede the board from being fixed directly against the subframe.

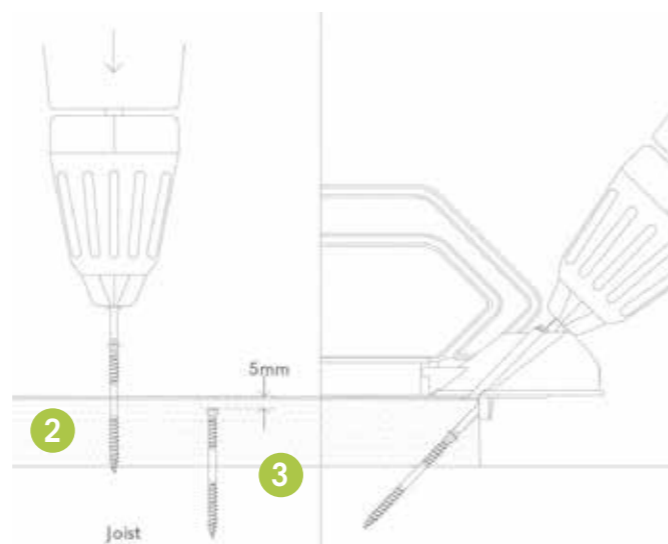

For best results, coat the fixings in silicone spray before use. When screwing in, push firmly on the screw whilst applying pressure to the board (2), finishing the screw head 5mm below the Lastane® surface. This should leave a minimal witness mark (3).

Failure to use our Durafix fixings with the bit provided or not fitting according to these guidelines may invalidate the warranty and affect the overall look of the deck. Two fixings per board should be used where the board crosses a joist, we advise to use three at the ends of the boards.

The fixings at the ends of the boards should be fixed at a slight angle to prevent being too close to the end of the board (4), positioning the screws 20-25mm from the ends and 20mm minimum from the sides of the boards. Board ends should be supported by a minimum of 20mm (5).

Cuts must always be positioned over the joist. As the boards are manufactured through a moulding process we recommend that all ends are squared off with a slight back cut of around 2-3 degrees before they're installed (6).

We recommend a 4mm space between the sides of boards and 1mm gap at the ends on butt joints, a 10mm gap should be left between the boards and any solid surface to facilitate drainage.

Start installing the first row of boards to a string line, fix the boards at one end, then a fixing in the middle adjusting spacing as necessary with the Millboard Multi-Spacers (7).

Then fix to the remaining joists. We recommend checking the boards against the string line every 4-5th row. As there may be slight variation in width, length and thickness, packers can be used to create a flat finish between two boards. Therefore it is best for screws to be left at butt joints until both boards are together.

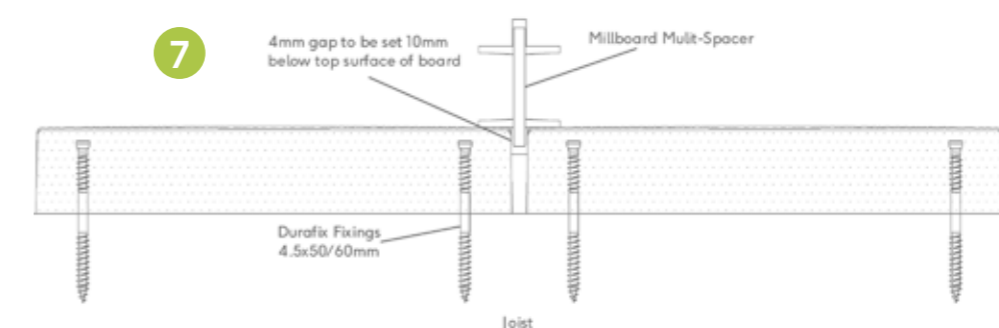
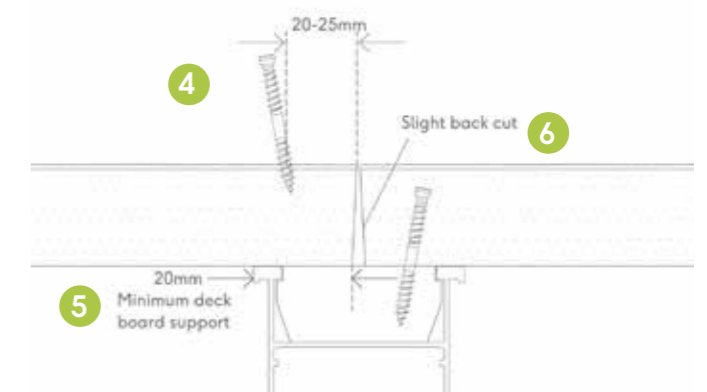

Fascia boards, steps and edges

We recommend that our purpose-made edgings are fitted to all steps and perimeters of the deck, as they're coated with extra Lastane for added resilience on these areas.

If the edging profiles aren't being used, any visible cuts need to be coated with Millboard Touch-up Coating.

When mitring the edging or fascia profiles for a corner, it is best to cut the mitre from the centre of the board to account for natural variance in grain and sizing. When gluing the mitred edges together, we recommend using PU wood glue for the core and a super glue for the Lastane.

When two edging/fascia lengths come together along the deck, these should be put together on a 20 degree angle back cut so that one piece slides over the top of the other. These angles should be painted with touch-up coating before being fixed to the framework.

The 150mm edging is a board with a bullnose to the front edge called the Bullnose Board. The 50mm edging is available in the Square profile or in a flexible bullnose profile.

If using the 50mm wide edgings, ensure they are supported on a joist by a minimum of 25mm (8).

The maximum overhang for the 50mm edging is 9mm, for the 150mm Bullnose Board the maximum overhang is 40mm (9).

The Flexible Bullnose and standard Fascias will bend to a radius of 1.2m. These profiles need to be at least room temperature (c.20°C) to bend to this radius.

When fixing the flexible edging and fascia, start from the end with a double fixing point and work along, fixing at 200-300mm intervals as you go. Some fixing holes may be partially visible.

All edging and fascia profiles need to be fully supported along their length and fixed at 300mm centres.

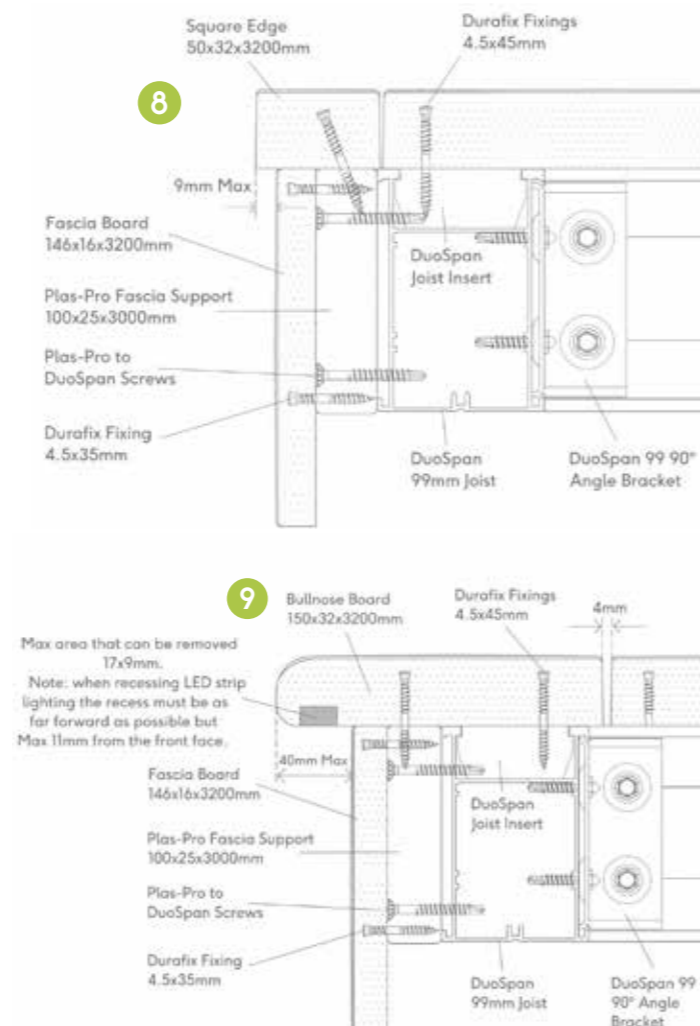

Taking care

If the board surface becomes dirty during installation, this should be cleaned as soon as possible using warm soapy water and a brush.

Clean your decking when required to remove leaves and general dirt particles. Cover the boards from any surrounding building works or painting that could mark the surface of the boards.

Stubborn marks may be removed with a range of different cleaners depending on the mark. Please contact us for more information on [02476 439 943](tel:02476439943).

After Care

Now that your Millboard is installed, make sure it stays in premium condition with our handy tips on aftercare.

Factory sealed

Millboard decking boards are surface sealed in the factory to ensure they arrive in premium condition. In the first few weeks of use, rainwater will sit on the surface in globules, but don't worry – this is normal and will stop once the temporary surface seal breaks down.

Marking

The Lastane® finish is resistant to food and drink stains and scratches, and everyday wear and tear. Sharp objects such as unprotected table or chair legs, spiked shoes, animal claws or metal planter bases can leave marks if dragged across the surface, so take care when moving these items around.

Winter ice and snow

A small amount of granulated white salt can be used to keep your Millboard ice-free. Please don't use rock salt, as this contains clay and grit and can be dirty and abrasive. When winter's over, clean the surface with soapy water and a brush.

Cleaning

Remove spills and marks with plenty of water, a mild detergent and a cloth or brush (no solvents, chemicals or abrasive cleaners needed). Strong dyes and stains that fall on your decking, such as berries and animal droppings, should not be left. Remove these as soon as possible to prevent marking.

Frequently asked questions

Where can I use Millboard decking?

Millboard decking is extremely versatile and can be used in practically every outdoor space (subject to building control).

Create decks, cladding, balconies, roof gardens, boardwalks, bridges, pontoons, seating, steps, planters and more.

Millboard can be used as the decorative face for most outdoor designs, as long as it is fixed to a structural element.

Does it expand or contract?

As Millboard is made from a resin mineral composition it is stable in comparison to timber or composites based on timber, the amount of movement that is acceptable is up to 0.2%.

We recommend a 4mm gap between the sides of boards and a 1mm gap between the ends of boards, a 10mm gap should be left between the boards and any solid surface to aid drainage.

Can I use a pressure washer?

Pressure washers can be used on Millboard, with a psi of no greater than 2000.

A fan tip should be used with a 40 to 60 degree spread, keeping the head 250-300mm away from the surface.

Please note that using pressure washers may increase the chance of screw holes becoming more visible, test in an inconspicuous area first.

Direct, prolonged contact could damage the surface of the boards.

My boards have just been laid and have a slight oily/shiny finish?

As the boards are a moulded product we use a release agent in the manufacturing process so when the boards are first delivered this release agent is still on the surface.

This may result in the boards looking like they have a shiny or waxed surface or have small particles of dirt and water puddling.

This release agent will come off the surface within 6-8 weeks due to natural weathering.

This process can be accelerated by

cleaning the boards with warm soapy water and stiff brush after installation.

Can you use it for load bearing applications (i.e. structural)?

It is not recommended to use Millboard decking in structural applications. Millboard decking would need to be fixed to a structural frame, either made from DuoSpan, Plas-Pro or timber.

Does Millboard decking get hot in the sun?

As with all solid composite products, the surfaces tend towards heat retention making them warmer.

Darker colours will feel hotter and may be uncomfortable to walk on under direct sunlight and high temperature, footwear may be necessary in these circumstances. Special caution should be taken when using decking in areas by heat/UV reflective glass.

What tolerances should be allowed?

There will always be a slight variance in the board's dimensions due to the fact that we mould from natural oak, and due to the pressure of the moulding process. Despite this, we calibrate the boards to maintain as consistent a profile as possible.

The manufacturing tolerances are: Width: ± 3 mm. Length: ± 5 mm. Thickness: ± 2 mm.

The dimensions of the Weathered Oak style may vary more between moulds due to the fact that they are moulded from timeworn oak with minimal changes to the dimensions.

When working with the boards, packers may be required to create a flush finish between two boards.

What fixings should be used to fix Millboard decking?

Following extensive trials, we recommend and supply Durafix stainless steel screws, designed specifically for Millboard - this is a requirement of our limited warranty.

There's no need to pre-drill or countersink Millboard decking, and the unique Lastane material coating flexes back over the screw-heads, leaving a minimal witness mark.

This may be more visible on the lighter colours. Should some of the screws leave larger witness marks, these can be filled - please see our installation guide.

Can I use a standard board as an edging piece?

Yes you can, only where the edge is merely aesthetic, such as a balcony edge, if this is your preferred finishing option.

However, where the edge is likely to sustain impact, such as a step, we do not recommend using a standard board.

Our edging boards have been specifically designed with high impact in mind and as such have a thicker Lastane surface to withstand the knocks and scrapes associated with step edges and other associated applications.

Can I use a fire pit/bowl or patio heater on my deck?

In instances where there is burning wood or coal they will need to sit the fire bowl/brazier onto a porcelain or cement tile/slab. The slabbed area needs to extend about 1m outside the fire bowl/brazier.

Any embers or burning material needs to be removed immediately to prevent any damage or lasting marks to the Millboard surface.

Patio heaters or infra red heaters are not known to affect the boards.

Does Millboard decking come with a warranty?

Yes. Our Limited Warranty gives you peace of mind and we assure you that we will stand by the provisions, as laid down in the Limited Warranty document.

We will issue you with either a Residential 25 year Limited Warranty or a Commercial 5 year Limited Warranty depending on the installation application of the boards and when it is registered within 90 days of the installation.

For more information, visit millboard.co.uk/warranty

Something else?

For any other technical, installation or care questions:

- Visit www.millboard.co.uk
- Call our Technical Team on **024 7643 9943**
- Email us at technical@millboard.co.uk



The Millboard Company Ltd
UK Head Office:
Unit A, Castle Court,
Bodmin Road,
Coventry CV2 5DB
Registration Number: 06061318

E: enquiries@millboard.co.uk
T: 024 7643 9943

249F2SHe - 0121